

# MODEL RV METAL BUILDING RIDGE VENT

**SPECIFICATIONS:**

- 10' LENGTH
- VARIABLE PITCH UP TO 6:12
- LONG LIFE OPERATOR AND 15' CHAIN TO OPERATE AND LOCK DAMPER
- 26 GA SMP OFF WHITE PRE FINISHED SHEETING
- EXTRA WIDE SKIRTS
- 1/2" MESH GALVANIZED BIRD SCREEN
- HEAVY DUTY BANDED WOOD CRATE

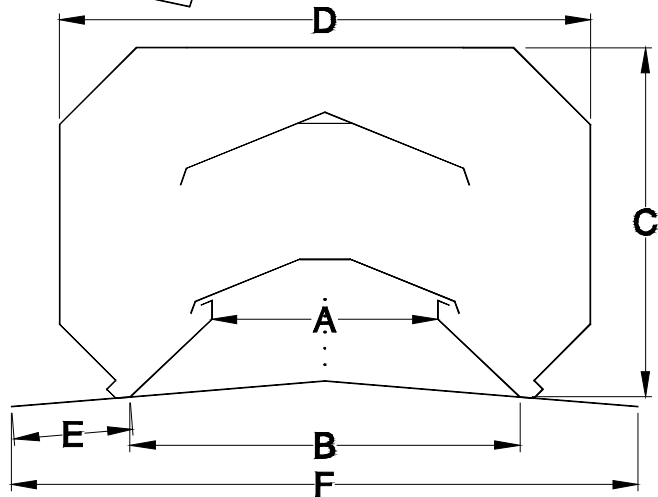
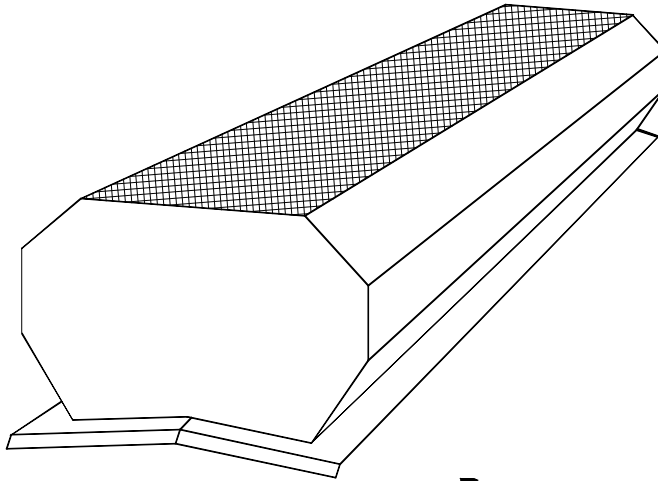

**OPTIONS:**

- CONTINUOUS OPERATOR KIT
- GALVALUME STEEL
- NO DAMPER OPTION
- INSECT SCREEN
- METAL CLOSURES
- MASTIC
- SEALANTS
- FASTENERS

<b>MODEL</b>	RV9	RV9	RV9	RV12	RV12	RV12	RV18	RV18	RV18	RV24	RV24	RV24
<b>HEIGHT</b>	10'	20'	30'	10'	20'	30'	10'	20'	30'	10'	20'	30'
<b>TEMP DIFF 10</b>	1568	1814	2003	2091	2419	2671	3136	3628	4006	4182	4838	5342
<b>20</b>	1814	2162	2429	2419	2883	3239	3628	4324	4858	4838	5766	6438
<b>30</b>	2003	2429	2757	2671	3239	3675	4006	4858	5514	5342	6478	7350

CFM CAPACITIES BASED ON 5 MPH WIND AND FRESH AIR INTAKE AREA OF 1-1/2 TIMES VENTILATOR OPEN AREA

MODEL	DIM A	DIM B	DIM C	DIM D	DIM E	DIM F	FINISH	DAMPER	QTY
RV-9	9"	15-1/2"	14"	21-1/4"	6-1/4"	28"			
RV-12	12"	20-3/4"	18-1/8"	28-1/4"	5-7/8"	32-1/2"			
RV-18	18"	31-1/2"	28-1/2"	41"	8-1/4"	48"			
RV-24	24"	44-1/4"	37-1/2"	54-1/4"	9-7/8"	64"			

PROJECT \_\_\_\_\_  
 LOCATION \_\_\_\_\_  
 DATE \_\_\_\_\_

CONTRACTOR \_\_\_\_\_  
 APPROVED BY \_\_\_\_\_  
 DATE APPROVED \_\_\_\_\_

## R & S MANUFACTURING AND SALES COMPANY, INC.

3575 Old Conejo Road, NEWBURY PARK, CA 91320  
 PHONE 805-375-3980 FAX 805-375-3981

## MODEL RV INSTALLATION DETAILS

1. Uncrate vent and place upside down. Cut end cap to match building pitch if greater than 1:12.

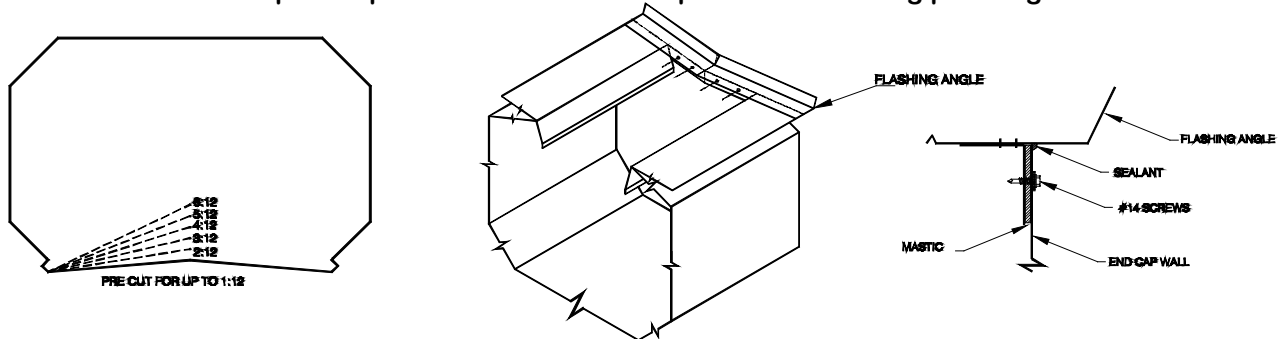

2. Apply sealants to end cap flashing. Secure end cap flashings (or multiple vent flashing where needed) with fasteners. Vents may be placed together to provide a continuous run.

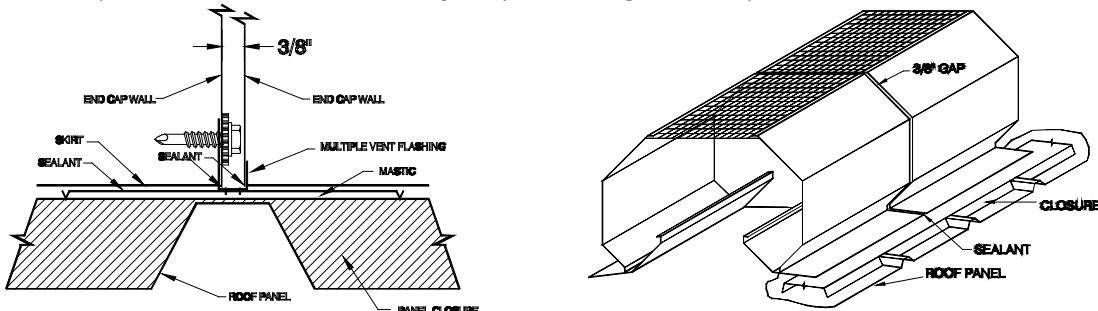

3. Locate vent a minimum of 1' from endwall and place closures on either side of ridge line. Seal closures on roof panel opening side.
4. Drill pilot holes through vent skirt (both sides) a minimum of 12" on center.
5. Seal closures with 1" wide mastic and gun grade per building supplier's recommendations.
6. Locate vent over closures and opening, drill pilot holes through skirt, closures, and roof panels. Secure fasteners along sides.
7. Vents are shipped with all individual damper drive components installed. Remove operator chain from container, and connect to lifter arm guide. Chain provides a 15' drop.

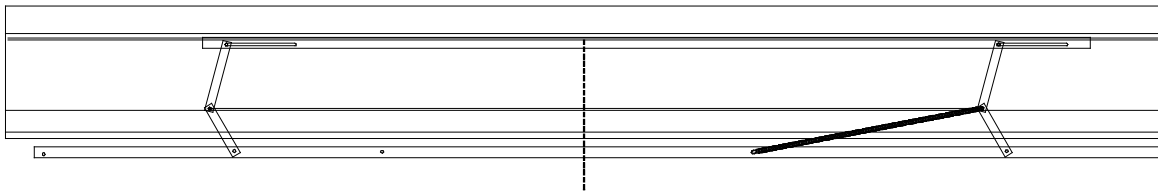

8. Dampers may be connected together with a special drive kit (ordered separately). The end unit operator may be used to drive up to 5 dampers (varies by size). Turnbuckles are used to connect damper pull bars together.

### R & S MANUFACTURING AND SALES COMPANY, INC.

3575 Old Conejo Road, NEWBURY PARK, CA 91320  
PHONE 805-375-3980 FAX 805-375-3981