

MODEL SFDD-LO-MB7 METAL BUILDING SKYLIGHT

SPECIFICATIONS:

DOUBLE DOME (MEDIUM WHITE OVER CLEAR)

METAL RETAINING CAP

CONDENSATE GUTTER

INSULATED 18 GAUGE NON-PITCHED ALUMINIZED STEEL MB CURB

6" UPSLOPE CURB HEIGHT

ALL WELDED CURB CONSTRUCTION CORNERS WELDED

UPSLOPE FLANGE WITH "UNDER" CONTOURS AND A WATER DIVERTER

DOWNSLOPE WITH "OVER" CONTOURS

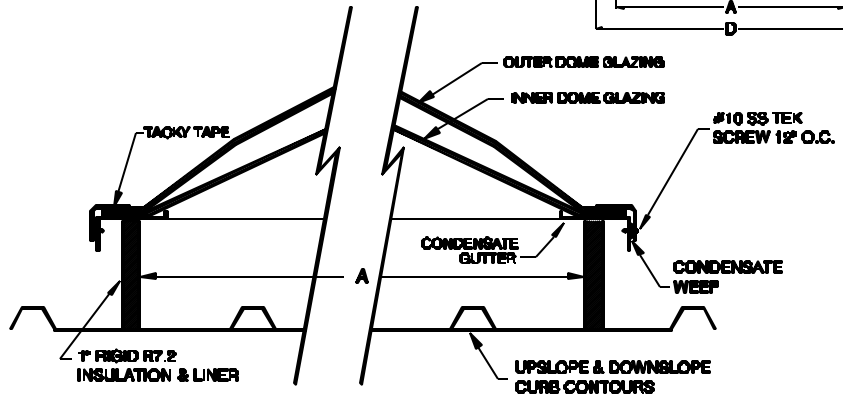
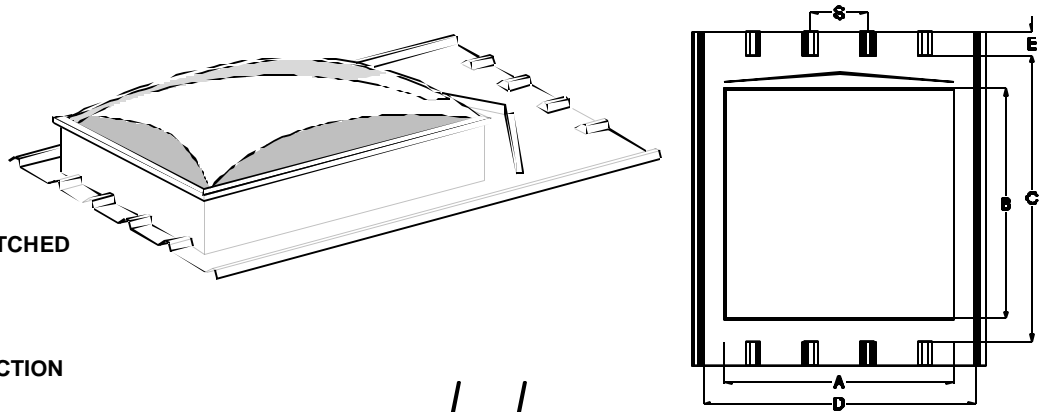

OPTIONS:

OUTER DOME GLAZING
 COPOLYESTER ARCHED DOME

INNER DOME GLAZING
 CLEAR

ICC LISTED

POWDER COAT FINISH (CURB ONLY) -
 WHITE
 CUSTOM COLOR

SPECIAL HEIGHT

SPECIAL RIB PLACEMENT

WIDE FLANGES
 UPSLOPE
 DOWNSLOPE

CRICKET IN LIEU OF DIVERTER

SUB FRAMING

2-1/2" WIDE MASTIC

MODEL	INSIDE CURB DIM A	CURB DIM B	DIM C	DIM D	DIM E	QTY
SFDD54102	48"	96"	105"	3"	111"	
SFDD5252	46-1/4"	46-1/4"	55-1/4"	3"	61-1/4"	
SFDD2828	22-1/4"	22-1/4"	28-1/4"	3"	34-1/4"	
SFDD3636	30-1/4"	30-1/4"	36-1/4"	3"	42-1/4"	
SFDD4242	36-1/4"	36-1/4"	45-1/4"	3"	51-1/4"	
SFDD4252	36-1/4"	46-1/4"	55-1/4"	3"	61-1/4"	
SFDD4276	36-1/4"	70-1/4"	79-1/4"	3"	85-1/4"	
SFDD4364	37-1/4"	58-1/4"	67-1/4"	3"	73-1/4"	
SFDD5276	46-1/4"	70-1/4"	79-1/4"	3"	85-1/4"	
SFDD6464	58-1/4"	58-1/4"	67-1/4"	3"	73-1/4"	
SFDD6476	58-1/4"	70-1/4"	79-1/4"	3"	85-1/4"	
SFDD6496	58-1/4"	90-1/4"	99-1/4"	3"	105-1/4"	
SFDD7676	70-1/4"	70-1/4"	79-1/4"	3"	85-1/4"	
SFDD7696	70-1/4"	90-1/4"	99-1/4"	3"	105-1/4"	
SFDD9696	90-1/4"	90-1/4"	99-1/4"	3"	105-1/4"	

ROOF PANEL MANUFACTURER	PANEL MODEL

PROJECT _____
 LOCATION _____
 DATE _____

CONTRACTOR _____
 APPROVED BY _____
 DATE APPROVED _____

R & S SALES COMPANY, INC.
 3575 Old Conejo Road, NEWBURY PARK, CA 91320
 PHONE 805-375-3980 FAX 805-375-3981

MODEL SFDD-LO-MB7 & SFD-LO-MB8 INSTALLATION DETAILS

1. On a fully sheeted roof, mark centerline of roof opening.

2. Use centerline of major rib as a guide and lay out roof opening to match the curb "A", "C", "D" & "E" dimensions.

3. Cut roof opening per building manufacturer's recommendations. Slit upslope edges of rough opening ("E") for flange clearance at transition point.

4. Install structural support framing for curb and equipment loads. Keep inside dimension clear. A minimum of two parallel curb walls should be supported. Avoid cantilever sections in excess of 12".

5. Apply mastic or sealant tape at points where curb meets roof panel. Apply to roof panel at curb side, and downslope flanges. Apply to curb upslope flange. Use only accessories as recommended by the building manufacturer.

6. Press curb into place on the roof panel. Upslope flange goes under roof panel; sides and downslope over roof panel.

7. Fasten the curb to support structure through curb flange and roof panel using fasteners compatible with the roof system. Use a minimum of four fasteners per side on maximum 4" centers.

8. Check tightness of fasteners and general integrity of installation. Caulk perimeter edge of curb flanges to roof panel.

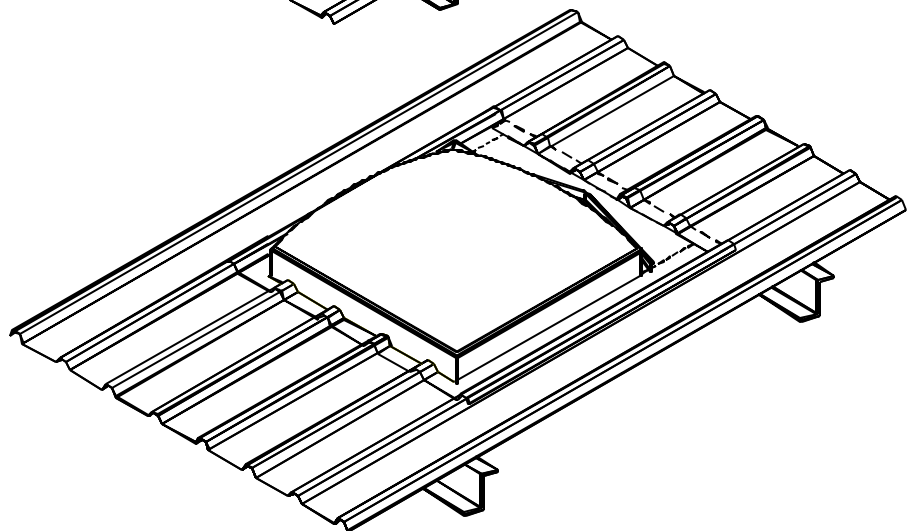
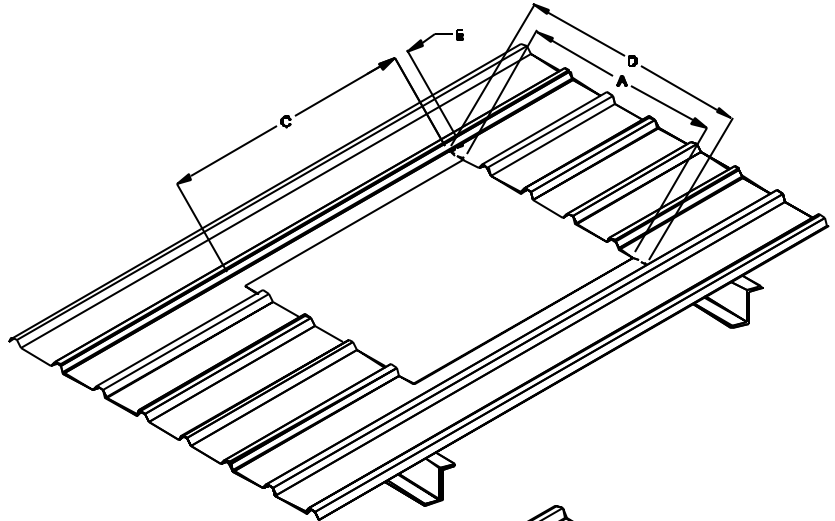

SIDE, & DOWNSLOPE SECTIONS

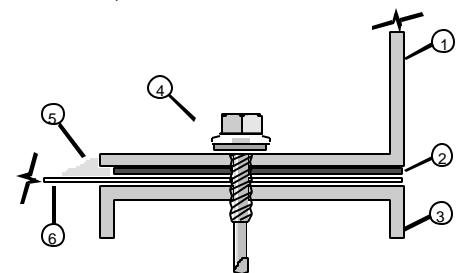

UPSLOPE SECTION

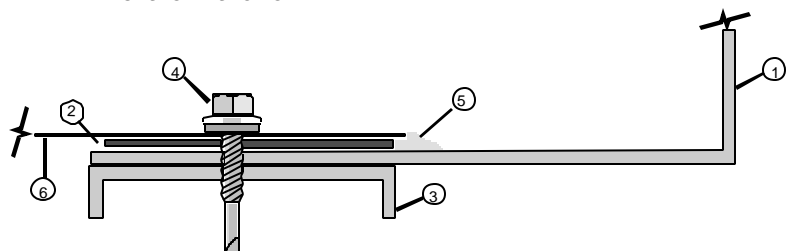

- 1. ROOF CURB WALL
- 2. TAPE MASTIC
- 3. SUPPORT FRAMING
- 4. COMPATIBLE FASTENER
- 5. SILICONE/URETHANE SEALANT
- 6. ROOF PANEL

R & S SALES COMPANY, INC.

3575 Old Conejo Road, NEWBURY PARK, CA 91320
PHONE 805-375-3980 FAX 805-375-3981