

# MODEL ST GRAVITY RELIEF-INTAKE VENTILATOR

**SPECIFICATIONS:**

**FOR GRAVITY RELIEF OR INTAKE VENTILATION**

**MILL FINISH GALVANIZED CONSTRUCTION**

**WEATHERPROOF AND STORMPROOF UNDER  
NORMAL OPERATING CONDITIONS**

**THROAT SIZES 12" TO 96"**

**1/2" MESH 19 GAUGE GALVANIZED BIRDSCREEN**

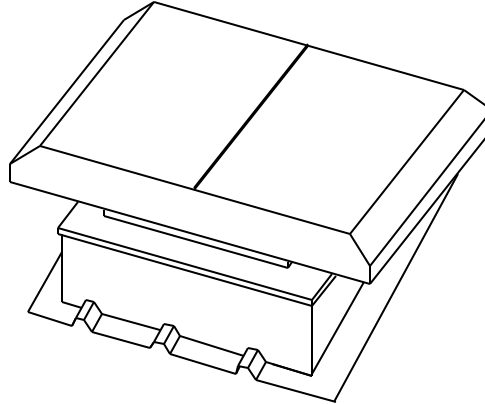

**OPTIONS:**

**ALUMINUM CONSTRUCTION**

**INTEGRAL METAL BUILDING BASES**

**CURB MOUNT BASE**

**BACKDRAFT DAMPERS**

**AIR DRY ENAMEL OR POWDER COAT FINISH**

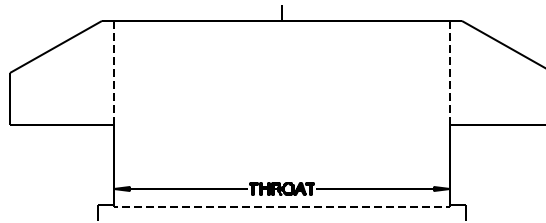

Velocity Ratings (Feet Per Minute)  
Static Pressure Drop (Inches Water Column)

Velocity FPM	300	400	500	600	700	800	900	1,000	1,100	1,200	1,300	1,400	1,500
Intake	.010	.017	.027	.038									
Exhaust	.014	.025	.039	.056	.077	.100	.127	.156	.189	.225	.264	.306	.352

QTY	MODEL	METAL BUILDING CURB - ROOF PITCH	PANEL MFG.	PANEL MODEL	SLOPE/RIDGE

PROJECT \_\_\_\_\_  
 LOCATION \_\_\_\_\_  
 DATE \_\_\_\_\_

CONTRACTOR \_\_\_\_\_  
 APPROVED BY \_\_\_\_\_  
 DATE APPROVED \_\_\_\_\_

**R & S SALES COMPANY, INC.**  
 3575 Old Conejo Road, NEWBURY PARK, CA 91320  
 PHONE 805-375-3980 FAX 805-375-3981